

The **DSV Check Valve** is a non-slam spring-assisted check valve designed to prevent flow reversal in industries with strict cleanliness codes. To accommodate various piping arrangements, the DSV Check Valve is available as a "Vertical" or "Horizontal" valve. The Horizontal valve is for Horizontal lines requiring a self-draining valve. The "Vertical" design is for "Vertical" installations and "Horizontal" lines when a self-draining valve is not required. The DSV Check Valve, with a 316L stainless steel body and seat, is fastened with a quick release clamp and elastomeric gasket body seal to permit fast and easy access to the internals. The disc and seat are lapped to provide excellent shutoff.

Horizontal



Vertical



FEATURES:

- Meets 3A Standard 58-02
- Spring-assisted silent closing
- Horizontal or vertical installation
- Sizes 1/2" thru 4"
- 150 CWP, 108 ANSI Pressure Class
- 316L body and seat (A351 CF3M)
- 316 disc, spring and guide assembly
- 32 Ra Internal Surface Finish (#4 Ground Finish)
- Edge-guided disc: 1/2" thru 2"
- Edge/center-guided disc: 2 1/2", 3", 4"
- Lapped "metal" seat and disc
- Springs:
 - Low cracking pressures
 - .16 psig to .66 psig
 - Conical design
 - Electropolished finish
- Standard gasket body seal:
- EPDM (300°F max temperature)
- Optional gasket body seal:
 - Tuf-Flex[®] (1) (300°F max temperature)
 - Viton[®] (400°F max temperature)
- CIP (Clean in Place)
- Clamped ends
- Seat leakage per MSS SP-61
- Options:
 - 15 Ra Internal Finish

Horizontal

Vertical

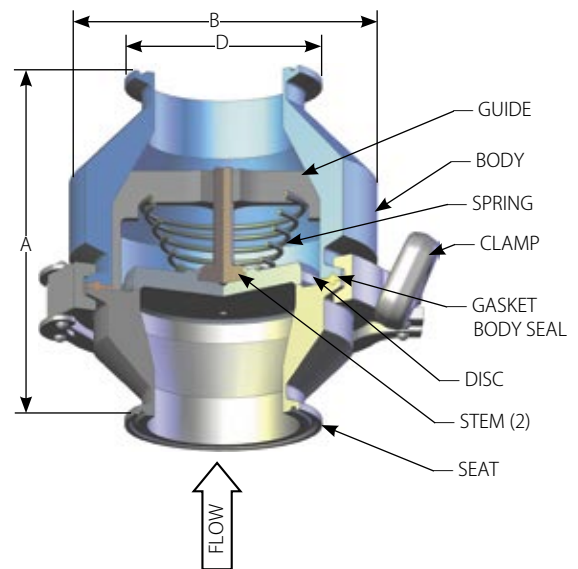
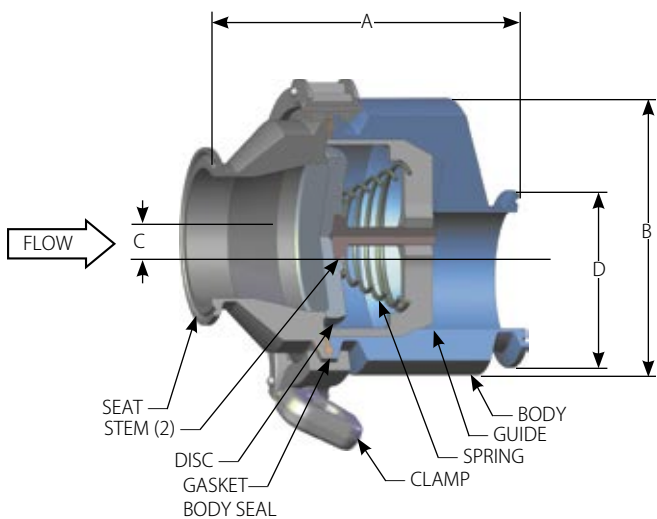

Consult pages 44 and 45 for Pressure/Temperature ratings and soft seat materials.

HORIZONTAL		
1/2"	A	2.50
	B (Dia.)	1.50
	D (Dia.)	0.98
	Weight	1.4
	C	0.44
	Cv	2.4
CP	0.29	
3/4"	A	2.50
	B	1.50
	D (Dia.)	0.98
	Weight	1.4
	C	0.31
	Cv	7
CP	0.29	
1"	A	3.48
	B (Dia.)	3.00
	D (Dia.)	1.98
	Weight	3.7
	C	0.50
	Cv	12
CP	0.36	
1 1/2"	A	3.67
	B (Dia.)	3.12
	D (Dia.)	1.98
	Weight	4.0
	C	0.50
	Cv	36
CP	0.28	
2"	A	4.41
	B (Dia.)	3.62
	D (Dia.)	2.52
	Weight	5.8
	C	0.50
	Cv	47
CP	0.23	
2 1/2"*	A	5.56
	B (Dia.)	4.75
	D (Dia.)	3.05
	Weight	11.2
	C	0.73
	Cv	69
CP	0.54	
3"*	A	4.88
	B (Dia.)	4.75
	D (Dia.)	3.58
	Weight	9.9
	C	0.48
	Cv	90
CP	0.54	
4"*	A	6.25
	B (Dia.)	7.00
	D (Dia.)	4.68
	Weight	22.2
	C	0.97
	Cv	137
CP	0.50	

VERTICAL		
1/2"	A	2.50
	B (Dia.)	0.98
	D (Dia.)	0.98
	Weight	1.4
	Cv	2.4
	CP	0.26
3/4"	A	2.25
	B (Dia.)	0.98
	D (Dia.)	0.98
	Weight	1.3
	Cv	7
	CP	0.26
1"	A	2.92
	B (Dia.)	2.00
	D (Dia.)	1.98
	Weight	2.3
	Cv	18
	CP	0.31
1 1/2"	A	3.29
	B (Dia.)	2.50
	D (Dia.)	1.98
	Weight	2.8
	Cv	38
	CP	0.23
2"	A	4.03
	B (Dia.)	3.00
	D (Dia.)	2.52
	Weight	3.9
	Cv	53
	CP	0.16
2 1/2"*	A	5.56
	B (Dia.)	4.00
	D (Dia.)	3.05
	Weight	9.9
	Cv	81
	CP	0.42
3"*	A	4.38
	B (Dia.)	4.00
	D (Dia.)	3.58
	Weight	6.1
	Cv	109
	CP	0.42
4"*	A	5.50
	B (Dia.)	6.00
	D (Dia.)	4.68
	Weight	14.9
	Cv	174
	CP	0.40

MATERIALS OF CONSTRUCTION

COMPONENT

Body	A351 CF3M
Seat	A351 CF3M
Disc	316 SS
Spring	316 SS
	(electropolished)
Guide Assembly	316 SS
Gasket Body Seal	EPDM**
	(-75°F to 300°F)
Clamp	304 SS

** Other gasket body seal materials available upon request

PRESSURE/TEMPERATURE RATING

Temp. (°F)	Pressure	Material Temp. Limit
100	150	
200	125	
300	115	EPDM, Tuf-Flex [®] (1)
400	105	Viton [®]

Notes: 1. PTFE grafted to an EPDM rubber inner core. Good for steam applications. Meets USDA, FDA and 3A Sanitary Standards and U.S. Pharmacopeia Class VI Certification.

2. Sizes 2 1/2", 3", 4"

* Edge/Center Guided Disc

All dimensions are in inches. Weights are in pounds. For metric measurements, visit www.dft-valves.com. CP: Cracking Pressure (psig)